

# FITTING INSTRUCTIONS

## Spin-on filter adaptors MGC

Partnumber: 011.205

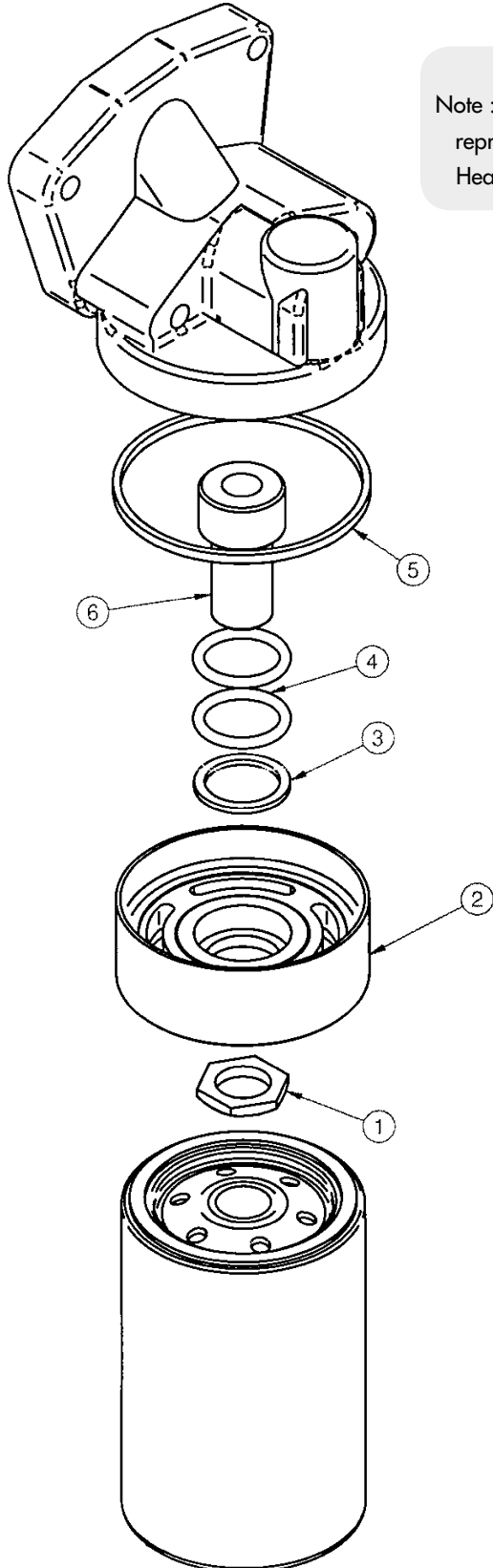

### Filter Head

Note : The Filter Head shown is a Schematic representation of a Filter Head, the Filter Head on your car may not look like this.



To compensate for the variations in Filter Head tolerances the

Spin On Consists of three parts Spin On Inner and Outer and an O ring. The variations in tolerances are taken up by the Spin On Outer sliding over the Spin On inner. The integrity of the seal between the Inner and Outer is maintained by an O ring.

### Fitting instructions

- Remove existing oil filter bowl, sealing ring and splash plate. Place the sealing ring (item 5) in the Filter Head recess. Fit the Extension Screw (item 6) to the Filter Head.
- Apply grease to the O rings (item 4) and to the seal (item 3) and then fit as indicated to the Spin On assembly (item 2).
- To ensure that the inner' O ring (item 3) is seated correctly. slide the Spin on outer over the Spin On Inner so that the outer seal face sits back from the Filter Head seal when the unit is assembled to the Filter Head.
- Secure the assembly to the Filter Head with the nut (item 1), tighten the nut until the O ring contacts the seal face then tighten a further of a turn. Push the Spin On Outer home. The oil seal between the Spin On Outer and the Filter Head will be created when the Oil Filter is fitted.
- Fit the Oil Filter in accordance with the manufacturers instructions.

We recommend oil filters with 3M" UNF thread and anti-drain valve, eg part nr. 011.131.

### Kit of Parts

- 1 off Nut (item 1).
- 1 off Spin On Assembly (item 2).
- 2 off O Rings 3.53mm dia (item 4).
- 1 off Seal (item 3).
- 1 off Seal (item 5).
- 1 off Spigot (item 6).